

ELECTRICAL SPECIFICATIONS

PART NUMBER	L_0 +15% -10% MILLI-H	DCR ±15% OHMS	DC AMPS FOR 70% L	MAX DC AMPS FOR 50°C RISE	SELF RES. FREQ.-kHz
EM40HL23	.40	.095	1.2	3.5	1500
EM40HL24	.63	.15	.96	2.8	1100
EM40HL25	1.0	.24	.76	2.2	840
EM40HL26	1.6	.38	.60	1.8	630
EM40HL27	2.5	.61	.48	1.4	470
EM40HL28	4.0	.97	.38	1.1	350
EM40HL29	6.3	1.5	.30	.90	260
EM40HL30	10	2.5	.24	.70	200
EM40HL31	16	3.9	.19	.56	150
EM40HL32	25	6.2	.15	.44	110
EM40HL33	40	9.8	.12	.35	84
EM40HL34	63	15	.10	.28	60

SCHEMATIC DIAGRAM

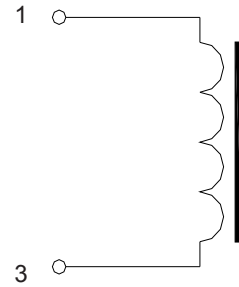

INDUCTANCE WITH DC

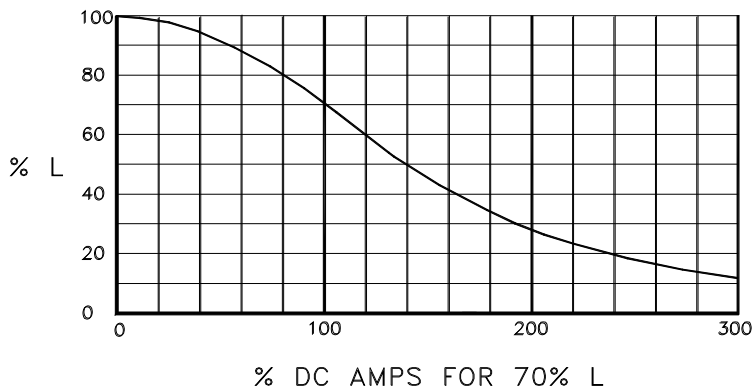

MECHANICAL SPECIFICATIONS

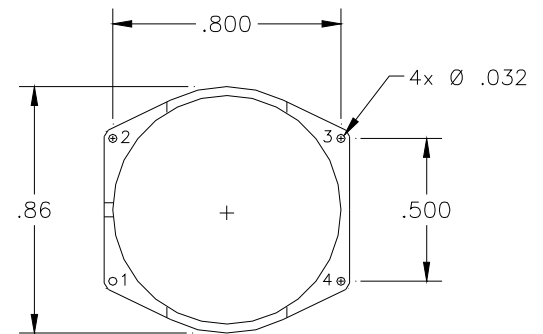
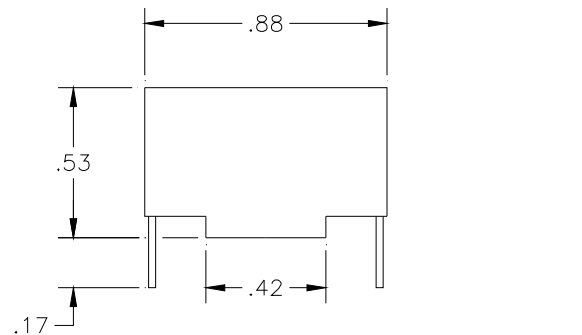

BOTTOM VIEW

NOTES

1. Initial inductance (L_0) is measured at 1 KHz.
2. DC Amps maximum rating is DC and RMS AC combined for a 50°C rise at an ambient of 20°C and with no heat sink.
3. Designed to meet MIL-PRF-27 Grade 5, Class S(130°C).
4. Self-Resonant Frequency is typical and for reference only.
5. For very low values of L & DCR, measure adjacent to case.
6. Pins are tinned copper.

	INIT.	DATE	CAGE	MAGNETIC CIRCUIT ELEMENTS INC. www.MCEmagnetics.com, ph. 831-757-8752, fax 831-757-5478				
PROD.	<i>MP</i>	2-12-10	09349					
ENG.	<i>JC</i>	2-12-10		TOROIDAL SWINGING CHOKES - NICKEL POWDER				
Q.A.	<i>B.T.</i>	2-12-10	TEST CONDITION 20° ± 5° C	DECIMALS (IN.) .XX = ± .03 .XXX = ± .010	VOLTS ±5%	FREQUENCY ±5%	SIZE A	DWG. NO. EMHL
REV.								