

APPLICATION FEATURES

- Reliability** - Designed to meet MIL-PRF-27 Grade 5, Class S (130°C).
- Low Profile** - Toroidal core permits minimum height and weight for rated power.
- Flexibility** - Through-holes permit terminal side to be mounted against or opposite mounting surfaces.
- High Efficiency** - Toroidal tape core permits design at high flux density resulting in minimum core and copper losses.

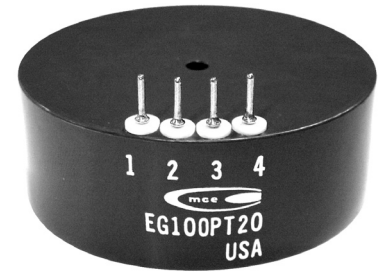

ELECTRICAL SPECIFICATIONS

P/N	POWER V-A	I SEC. AMPS	REG. PERCENT	EFF. PERCENT	T.R. ±2% PRI:SEC	RESISTANCE - Ω ±10%	
						PRI	SEC
EG50PT30	10	0.4	11	89	0.251	50	3.5
EG75PT23	31	1.2	3.7	96	0.236	6.4	0.44
EG100PT20	62	2.4	2.4	96	0.232	1.7	0.17
EG125PT17	125	4.8	4.0	95	0.229	0.62	0.087

SCHEMATIC

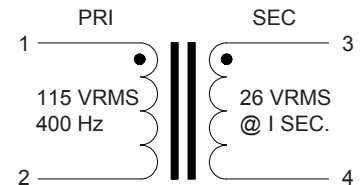

DESIGN FEATURES

1. Extended solid-pin terminals. This unique MCE design feature provides multiple values:
 - a. Susceptibility of internal solder joint to heating at time of external connection is minimized due to the long distance the heat must travel.
 - b. Unit contains only one solder connection per terminal instead of the conventional two for improved reliability.
 - c. Manufacturing method positions coil leads adjacent to terminals thus minimizing length of coil lead in plastic and eliminates need for flex leads.
 - d. Coil lead is mechanically wrapped around terminal and solder connection is exposed during assembly for inspection.
 - e. Terminals are precision located for use in printed circuit boards.
2. Encapsulation cup is high-temperature glass-filled for physical stability.
3. Epoxy encapsulation material is resistant to thermal and mechanical stress.

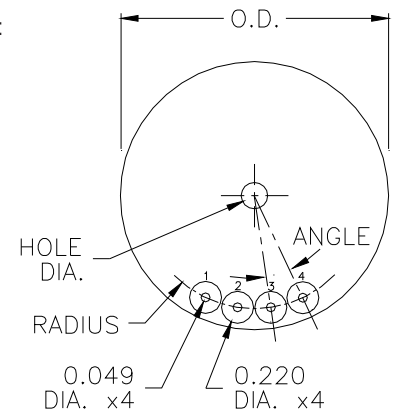

MECHANICAL SPECIFICATIONS

P/N	DIMENSIONS			TERMINAL LOCATION		WT.
	O.D. MAX	HEIGHT MAX	HOLE DIA.	RADIUS	ANGLE	GRAMS
EG50PT30	1.36	0.63	0.140	0.55	24.0°	40
EG75PT23	2.01	0.80	0.140	0.87	15.2°	120
EG100PT20	2.62	0.98	0.140	1.17	11.3°	250
EG125PT17	3.27	1.30	0.166	1.47	9.0°	540

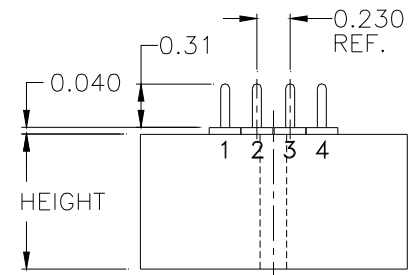

NOTES

1. Power (V-A) and secondary current (I) are based upon a temperature rise of 30°C above ambient.
2. Dielectric Withstanding Voltage is 500 VRMS, 60 Hz from primary to secondary.
3. Other voltages available as modified standard parts. Contact an MCE Application Engineer for further information.
4. If the terminals are inserted into a PC board, a 0.080 inch thick stand off washer is required to level the part. Add a 'W' to the end of the part number to include the washer as a separate item in the shipment.

	INIT.	DATE	TOLERANCES	MAGNETIC CIRCUIT ELEMENTS INC. www.MCEmagnetics.com, ph. 831-757-8752, fax 831-757-5478			
PROD.	JAP	2-19-10	DECIMALS (IN.) .XX = ± 0.03 .XXX = ± 0.010 ANGLE = ±0.5°				
ENG.	JC	2-19-10		115V : 26V, 400Hz TRANSFORMERS			DWG. NO. EGPT
Q.A.	BT	2-19-10	CAGE 09349				
REV.	C	2-19-10					