

ELECTRICAL SPECIFICATIONS

PART NUMBER	FREQUENCY kHz	DC INPUT VOLTS	SECONDARY VOLTS	SECONDARY AMPS	PRIMARY L - MIN MILLI - H	PRIMARY DCR ±10% MILLI - OHMS	SECONDARY DCR ±10% MILLI - OHMS	TRANSFORMER EFFICIENCY % @ FULL LOAD	FILTER L1 - MIN MICRO - H
EE17KT12	100	43 - 57	12	4.0	.75	88	20	99	1.6
EE17KT24	100	43 - 57	24	2.0	.75	88	61	99	6.4
EE20KT12	100	43 - 57	12	8.0	.50	52	20	99	.80
EE20KT24	100	43 - 57	24	4.0	.50	52	36	99	3.2

SCHEMATIC DIAGRAMS

EE17KT

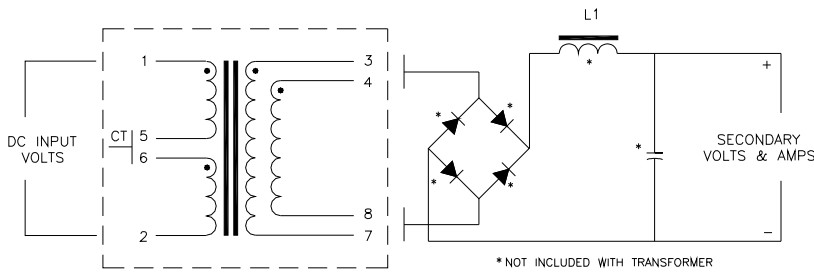

MECHANICAL SPECIFICATIONS

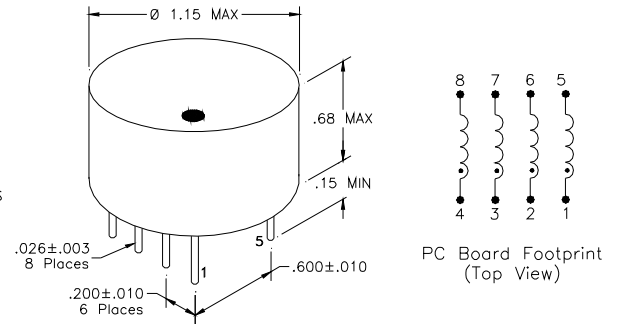

EE20KT

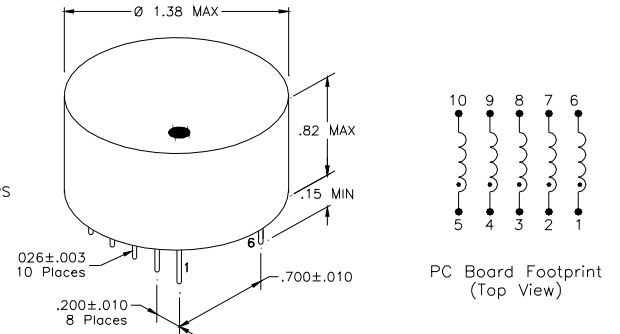
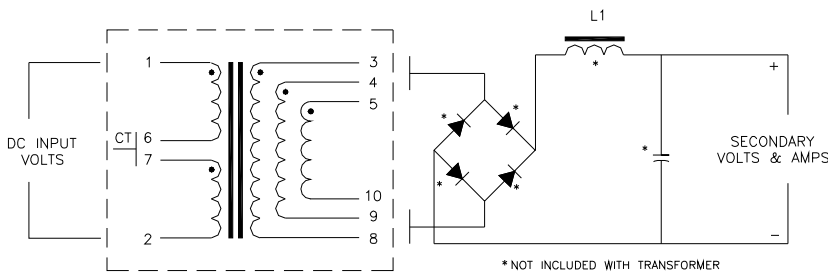

NOTES

1. Inductance and DCR values are for each winding.
2. Recommended filter inductance is for 200 kHz ripple.
3. UL3101 compliant with dielectric withstanding, etc.
4. Maximum operating temperature is 130°C.
5. All electrical data is at 20°C ±5°C.
6. Temperature rise is 30°C.
7. All mechanical dimensions are in inches.
8. Pins are hot solder dipped.

	INIT.	DATE	CAGE 09349	MAGNETIC CIRCUIT ELEMENTS INC. www.MCEmagnetics.com, ph. 831-757-8752, fax 831-757-5478 48 VOLT DC BUS PUSH-PULL TRANSFORMER					
PROD.	JAP	1-21-10							
ENG.	JC	1-21-10							
Q.A.	BZ	1-21-10	TEST CONDITION 20° ± 5° C	DECIMALS (IN.) .XX = ± .03 .XXX = ± .010	VOLTS	FREQUENCY ±5%	SIZE A	DWG. NO. EEKT	
REV.									